

Ölbrenner HL 120 A-S/B

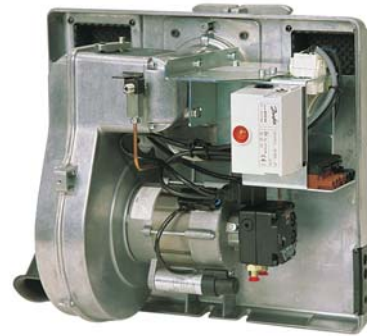

HL 120 A-S
HL 120 AV-S



Typ	Öldurchsatz	Leistung	Regelart	Bestell-Nr.
HL 120 A-S	4,0 - 10,0 kg/h	47 - 120 kW	einstufig	01200.00001
HL 120 AV-S	4,0 - 10,0 kg/h	47 - 120 kW	einstufig	01200.00011
HL 120 B	6,0 - 12,0 kg/h	71 - 140 kW	einstufig	01200.00021
HL 120 BV	6,0 - 12,0 kg/h	71 - 140 kW	einstufig	01200.00031

- HL 120 A-S: LowNO_x-Ausführung: Zulassung nach RAL-UZ 9 (Blauer Engel)
- automatische stellmotorangetriebene Luftabsperklappe (optional)
- Hochleistungsgebläse
- elektronisches Zündgerät
- Fotowiderstand zur Flammenüberwachung

HL 120 A..-S HL 120 B..

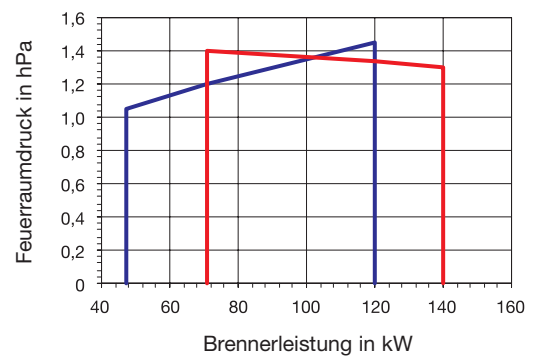

HL 120 A.-S

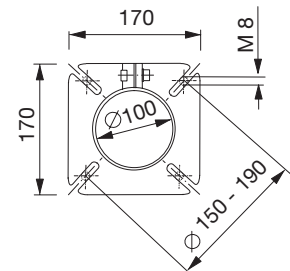
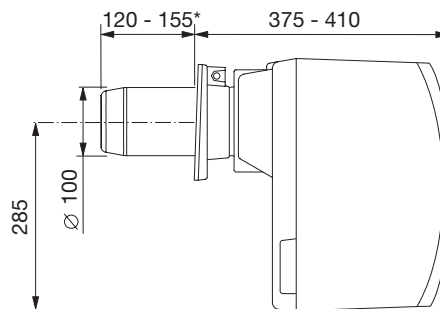
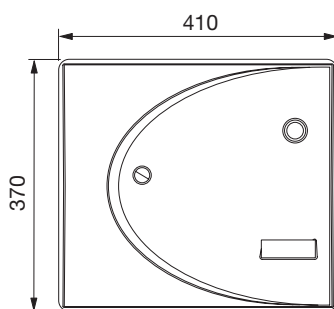

HL 120 B.

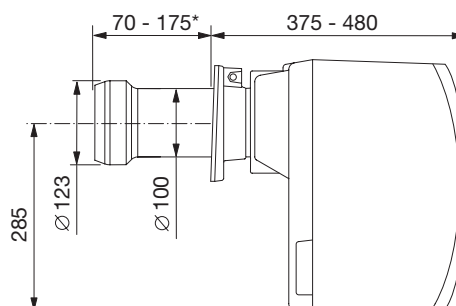

*andere Längen auf Anfrage

Verpackungsmaße (LxBxH):
425 x 485 x 595
Transportgewicht: 20,5 kg

alle Maßangaben in mm