

Oilburner HL 120 A-S/B

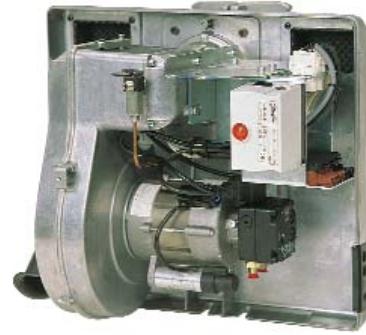

HL 120 A..-S



Type	Oil mass flow	Burner performance	Operating mode	Order-no.
HL 120 A-S	4,0 - 10,0 kg/h	47 - 120 kW	1-stage	5600
HL 120 AL-S	4,0 - 10,0 kg/h	47 - 120 kW	1-stage	5604
HL 120 AV-S	4,0 - 10,0 kg/h	47 - 120 kW	1-stage	5610
HL 120 ALV-S	4,0 - 10,0 kg/h	47 - 120 kW	1-stage	5605
HL 120 B	6,0 - 12,0 kg/h	71 - 140 kW	1-stage	5601
HL 120 BL	6,0 - 12,0 kg/h	71 - 140 kW	1-stage	5606
HL 120 BV	6,0 - 12,0 kg/h	71 - 140 kW	1-stage	5611
HL 120 BLV	6,0 - 12,0 kg/h	71 - 140 kW	1-stage	5607

HL 120 A..-S HL 120 B..

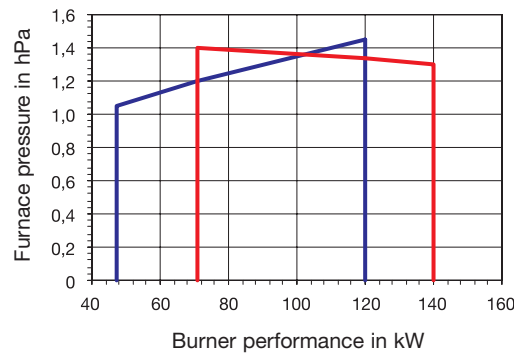

- HLZ 120 A-S: Low-NO_x-mixing unit certified according RAL-UZ 9 (Blue angel)
- High pressure fan
- Automatic air damper with servodrive on request
- Electronic ignition unit
- Photo resistor for flame detection
- Electronic ignition unit
- LE-system for reduced emissions during start up and stop

HL 120 A..-S

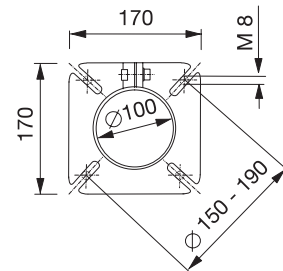
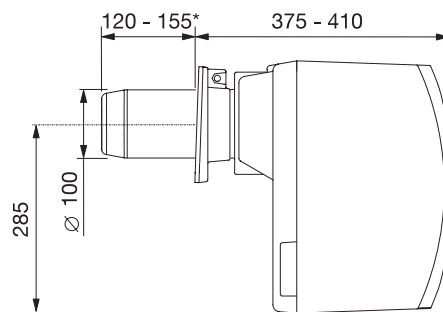
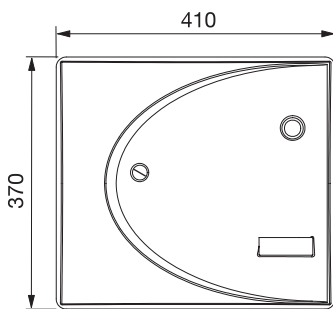

HL 120 B..

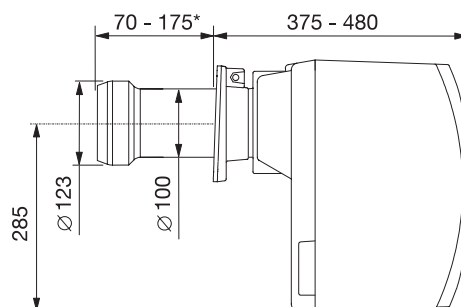

* Other lengths on request

Packing dimensions
(base x height):
425 x 485 x 595 mm
Transporting weight: 20,5 kg
All dimensions in mm